

AFF-20 / AFF-25

On-wall humidity sensor

RANGE

0~95 %

POWER

15 ... 36
V DC

OUTPUT

4-20mA
0~10V

Approvals



Messtechnik
Made in Germany

SPECIFICATION

MODEL	AFF-20 [plastic sinter filter] AFF-25 [metal sinter filter]
OUTPUT	DC4-20mA : 2 or 3-wire [3-wire for LCD backlight] 0-10V : 3-wire
POWER	15 to 36V DC
MEASURING RANGE	0 to 100% r.H.
OPERATING RANGE	0 to 95% r.H. [non-precipitating air]
DEVIATION	typically $\pm 1.8\%$ r.H. [10...90%] at +25°C, otherwise $\pm 2\%$ r.H.
AMBIENT TEMPERATURE	-30 ... +80°C, non-precipitating
SENSOR PROTECTION	AFF-20 : plastic sinter filter, Φ 16mm, L=35mm, exchangeable AFF-25 : pluggable measuring head [probe], metal sinter filter, Φ 16mm, L=88.5mm, exchangeable
PROTECTIVE TUBE	AFF-20 : stainless steel, Φ 16mm, NL=137mm AFF-25 : stainless steel, Φ 16mm, NL=88.5mm
CABLE GLAND	M16x1.5, max. inner diameter 10.4mm
PROTECTION TYPE	IP65 [according to EN 60529] enclosure only
ELECTRICAL CONNECTION	2-, or 3-wire connection 0.14 - 1.5 mm ² , via terminal screws on circuit board
PROCESS CONNECTION	by screws



AFF-20
with display



AFF-20
without display



AFF-25
with display



AFF-25
without display

| CO₂ | | HUMIDITY | | TEMPERATURE | | AC | | DC | | BATTERY | | OUTPUT | | CONTACT | | DISPLAY |

DIMENSION (mm)

※ 제품의 사양에 따라 변경 될 수 있습니다

AFF-20

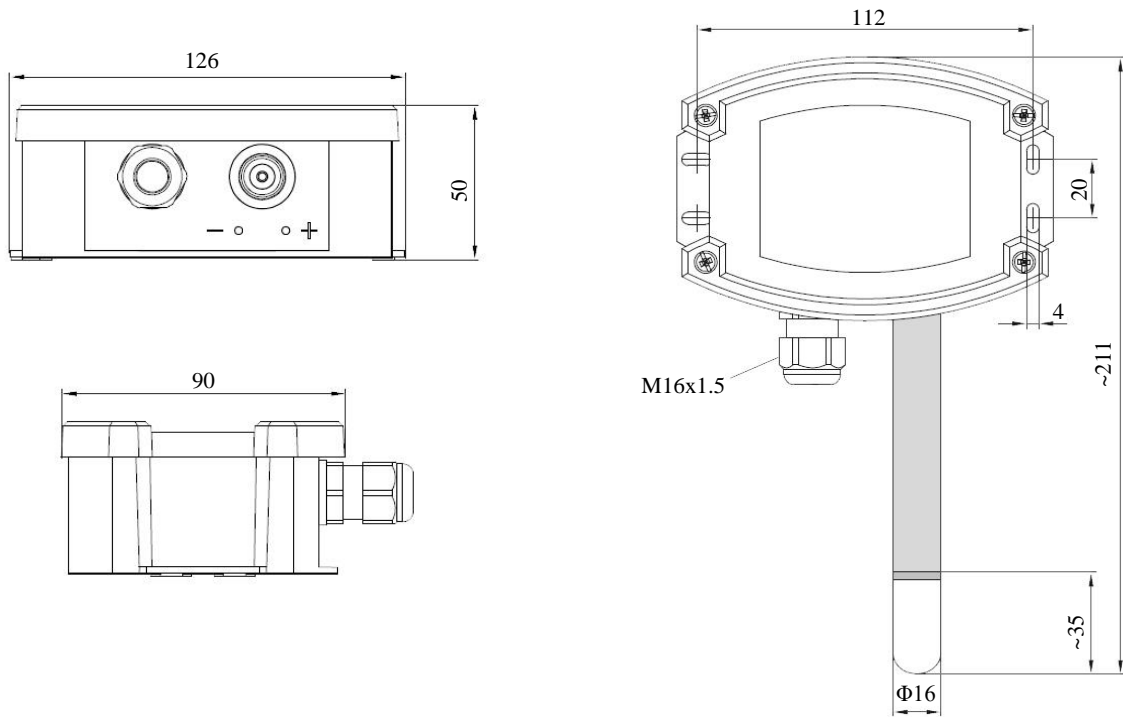

AFF-25

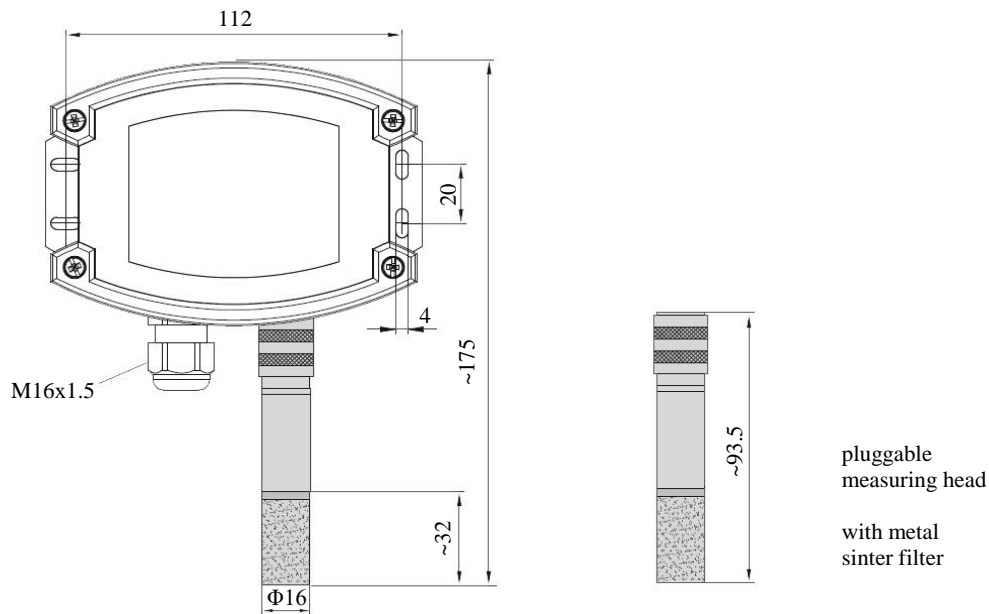

DIAGRAM

4-20mA 2 or 3-wire

1	+UB 24V DC
2	Output humidity in % r.H. 4-20mA
3	Free
4	-UB-GND [optional for backlighting]

0-10V 3-wire

1	+UB 24V DC
2	Output humidity in % r.H. 0-10V
3	Free
4	-UB-GND

Ordering Information

Code	Model
AFF-20	AFF-20
AFF-25	AFF-25

Code	Output
I	4-20mA
U	0~10VDC

Code	Display
1	Without
2	With

Complete Ordering Code

TYPE & IMAGE

	
<p>AFF-20-I-1 AFF-20-U-1</p>	<p>AFF-20-I-2 AFF-20-U-2</p>
	
<p>AFF-25-I-1 AFF-25-U-1</p>	<p>AFF-25-I-2 AFF-25-U-2</p>

| CO2 | HUMIDITY | TEMPERATURE | AC | DC | BATTERY | OUTPUT | CONTACT | DISPLAY