

Approvals:



CONNECTION

1"NPT
Female Thread

FLOW RANGE (N₂)

0 ~ 750 SLM
↓
0 ~ 2500 SLM

FLUID

Non-Corrosive
Dry Gases



SPECIFICATION

MODEL	TSF
APPLICATION	Non-Corrosive Dry Gases
FLOW RANGE	0 ~ 750 SLM ... 0 ~ 2500 SLM
PROCESS CONNECTION	1"NPT Female Thread
ACCURACY	< 2% F.S. / < 3% F.S.
REPEATABILITY	< 0.15% F.S.
RESPONSE TIME	< 1 Second
MATERIAL	Body : SS316 O-Ring : Viton / FFKM
OUTPUT SIGNAL	DC4-20mA / DC0~5V
MAX. PRESSURE	34.4 Bar
GAS TEMPERATURE	0 ... 50°C
POWER SUPPLY	24VDC / 15VDC
ELECTRIC CONNECTOR	9 Pin D-Sub
FLOW DIRECTION	Left to Right / Bottom to Top / Top to Bottom

DISPLAY

Code B



Code T



Code O



Code	Display
B	Flow Rate with Blue Back-Lighted LCD
T	Flow Rate & Totalizer with Blue Back-Lighted LCD
O	Without LCD

DECIMAL POINT

Flow Rate with LCD

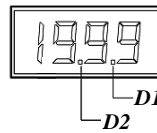

Range	Decimal Point
2.00 ~ 19.99	D2
20.0 ~ 199.9	D1
200 ~ 1999	None
2000 ~	X 10

Flow Rate & Totalizer with LCD

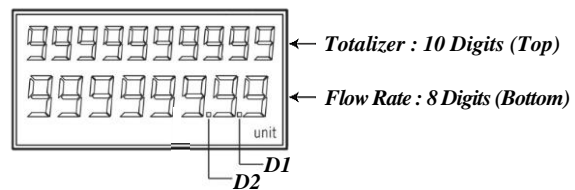

FLOW | PRESSURE | TEMPERATURE | AC | DC | BATTERY | CONTACT | DISPLAY

DIMENSION

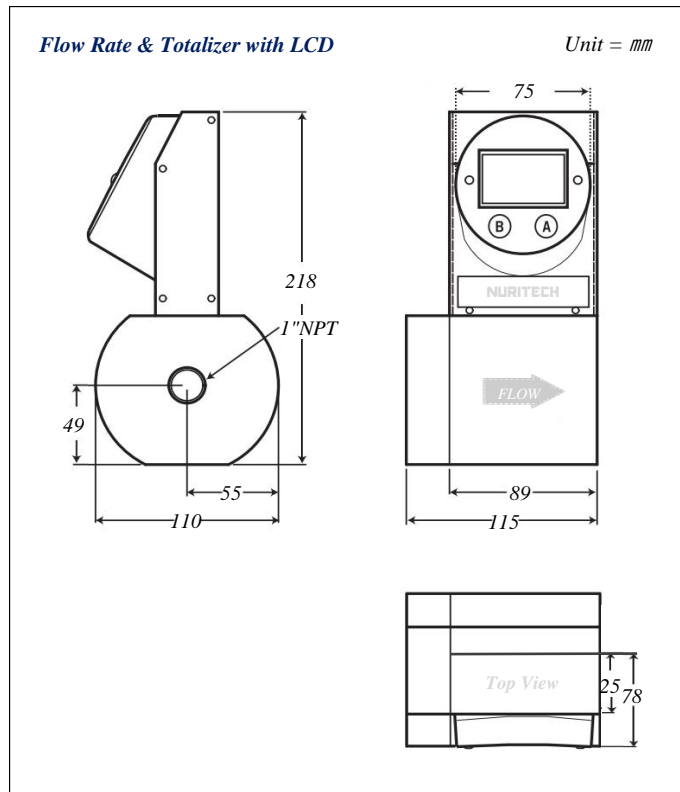
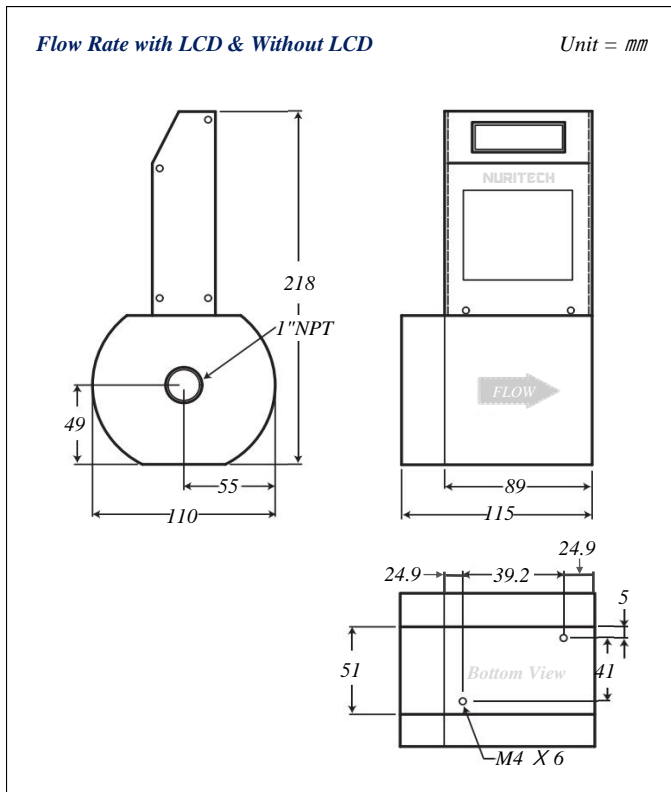



GAS FACTOR TABLE

* Please contact us the K Factor value of other gases

Actual Gas	Symbol	K Factor Relative to N ₂	Actual Gas	Symbol	K Factor Relative to N ₂	Actual Gas	Symbol	K Factor Relative to N ₂
Acetylene	C ₂ H ₂	0.58	Ethanol	C ₂ H ₆ O	0.39	Methyl Acetylene	C ₃ H ₄	0.43
Air	-	1.00	Ethyl Acetylene	C ₄ H ₆	0.32	Methyl Bromide	CH ₃ Br	0.58
Ammonia	NH ₃	0.74	Ethyl Chloride	C ₂ H ₅ Cl	0.39	Methyl Chloride	CH ₃ Cl	0.63
Argon	Ar	1.42	Ethylene	C ₂ H ₄	0.60	Nitric Oxide	NO	1.00
Bromine	Br ₂	0.81	Helium	He	1.43	Nitrogen	N ₂	1.00
Butane	C ₄ H ₁₀	0.26	Hexane	C ₆ H ₁₄	0.18	Nitrogen Dioxide	NO ₂	0.74
I-Butane	C ₄ H ₈	0.30	Hydrogen	H ₂	1.01	Nitrous Oxide	N ₂ O	0.71
Carbon Dioxide	CO ₂	0.74	Hydrogen Bromide	HBr	1.00	Oxygen	O ₂	0.99
Carbon Monoxide	CO	1.00	Hydrogen Chloride	HCl	1.00	Propane	C ₃ H ₈	0.36
Carbonyl Sulfide	COS	0.66	Hydrogen Sulfide	H ₂ S	0.80	Propylene	C ₃ H ₆	0.41
Chlorine	Cl ₂	0.86	Isobutane	CH(CH ₃) ₃	0.20	Silane	SiH ₄	0.60
Dimethyl Ether	(CH ₃) ₂ O	0.39	Isobutylene	C ₄ H ₈	0.30	Sulfur Dioxide	SO ₂	0.69
Ethane	C ₂ H ₆	0.50	Methane	CH ₄	0.72	Sulfur Hexafluoride	SF ₆	0.26

RELATED PRODUCTS

Model	Display	Input	Output	Power Supply
 <p>FCS Flow Indicator</p>	2 Lines Back-Lighted LCD Flow Rate & Totalizer	DC4-20mA	DC4-20mA Pulse RS485	24VDC
 <p>FDI Flow Indicator</p>	4-Digit Red LED Flow Rate only	DC4-20mA	DC4-20mA 2-Relay DC1~5V RS485	24VDC AC110/220V

FLOW RANGE (N₂)

* Flow rates are stated for Nitrogen

* For other gases use the K factor as a multiplier from gas factor table

Code	Flow Range	Accuracy
00	0 ~ 750 SLM	< 2.0 % F.S.
01	0 ~ 1000 SLM	< 2.0 % F.S.
02	0 ~ 1250 SLM	< 2.0 % F.S.
03	0 ~ 1500 SLM	< 2.0 % F.S.
04	0 ~ 2500 SLM	< 3.0 % F.S.
05	Custom Flow Rate (≤ 2500 SLM)	

ORDERING INFORMATION

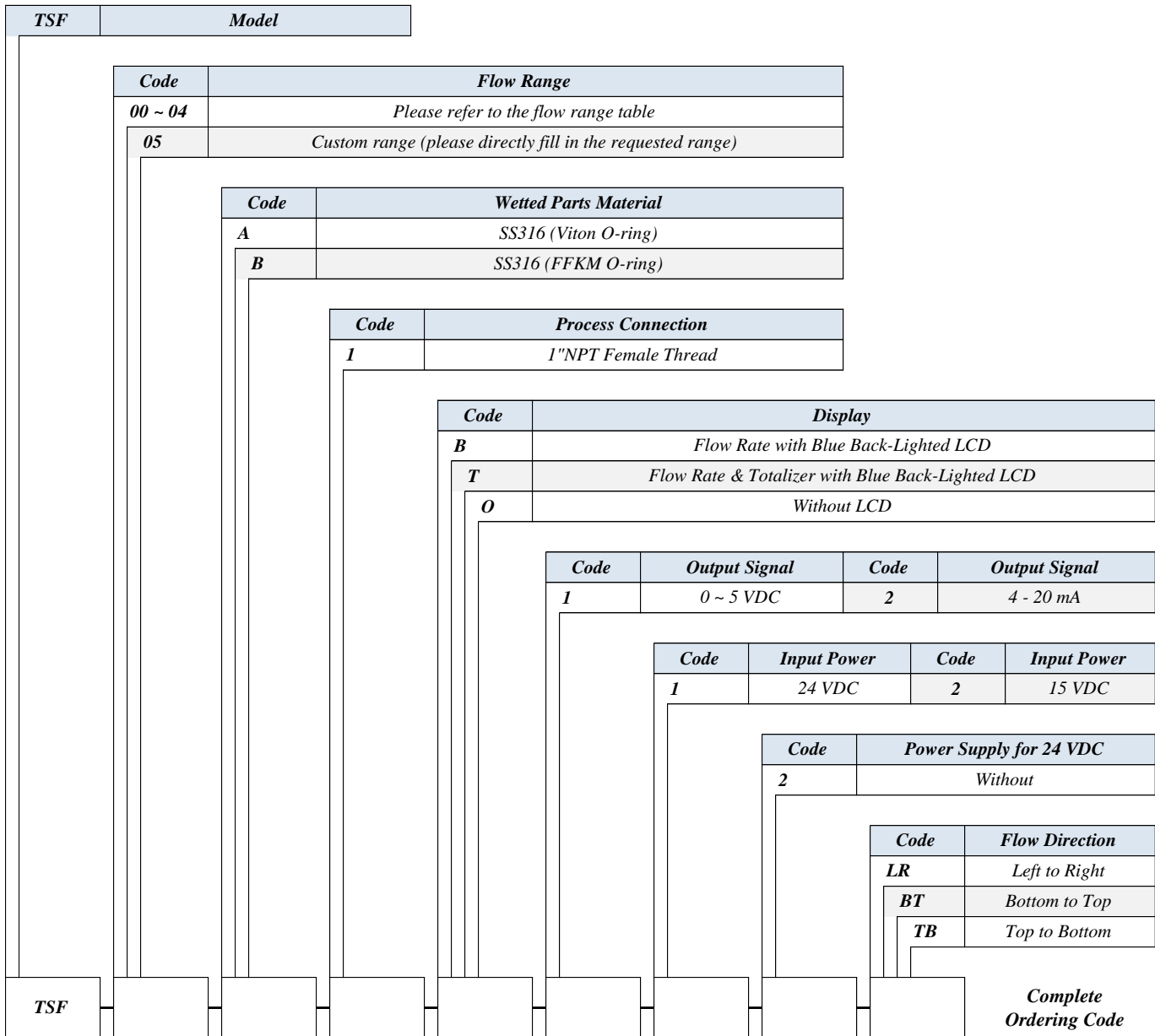

* Gas Name _____ Pressure & Temperature _____ Bar.G _____ °C (Normal)

| FLOW | | PRESSURE | | TEMPERATURE | | AC | | DC | | BATTERY | | OUTPUT | | CONTACT | | DISPLAY |